

Łukasz WARGUŁA*

Piotr KRAWIEC*

Konrad Jan WALUŚ*

Jakub POLASIK*

(Received 27 Oct 2017, Received in revised form 11 Jan 2017, Accepted 28 May 2018)

ELECTRONIC CONTROL IN INJECTION-IGNITION SYSTEMS IN PROPULSION OF NON-ROAD MOBILE MACHINERY

Propulsion of non-road mobile machinery dedicated for the waste wood chipping these are mainly internal combustion engines. Their construction mainly affects the efficiency of wood chipping processes. Liberal homologation regulations for combustion engines used by non-road mobile machinery lead not only to relatively high emissions of harmful exhaust gases but also do not force manufacturers to develop these types of machinery. These propulsions are not equipped with systems, structure and subassemblies that are characteristic of today's construction used in passenger cars that are highly efficient with low emissions to the environment. This article presents the most modern review of ignition-injection control systems to be used in spark-ignition internal combustion engines intended for the drive of non-mobile machinery. With a review of the fifty-seven manufacturers of this type of engine conducted in January 2017, only six offer engines with injection systems. Collected data of control systems referring to motor vehicles has shown that the constructions offered by manufacturers as innovative are constructions still significantly different from modern standards. In addition, the available systems for modernization of the systems and research projects were analysed. The results of the analysis will be the basis for modifying existing structures.

Keywords: non-road mobile machinery, mobile working machines, control of the internal combustion engine, injection and ignition system, spark ignition engine

1. INTRODUCTION

The branches of industry dealing with the processing of wood waste at a place where it is obtained constantly aim at improving the efficiency of these processes. [Fortuna-Antoszkiewicz et al. 2010, Tombesi et al. 2014, Szczepanowska 2015,

* Poznan University of Technology, Faculty of Machines and Transport.

Municipal Office in Gliwice 2017]. Literature as the main directions for increasing the efficiency of the process of chipping wood waste is system of automation or modification of existing equipment [Dias et al. 2015, Adamchuk et al. 2016]. For this purpose, research is carried out on existing construction, which significantly contributes to the efficiency of these devices [Przybylko 2013, Velazquez-Marti and Fernandez-Gonzalez 2010, Stassen 2015]. Various machine parts are examined in various aspects. Among published research concerning the effectiveness of exploitation a research that should be mentioned about was conducted in 2006 by Naimi, Sokhansanj, Mani, Hoque, Bi, Womac, Narayan [Naimi et al. 2006] who reviewed the construction of available on the market chippers as well as their energy consumption. Other scientists who analysed these constructions in 2010 were Nati and Spinelli [Nati and Spinelli 2010] and Nati, Spinelli and Fabbri [Nati et al. 2010] who checked real working conditions of chippers and the influence of wood species on process effectiveness. A year later (2011) Spinelli, Magagnotti, Paletto and Preti [Spinelli 2011] presented the result of research of the influence of wood characteristics such as: its species, humidity and parts of processed tree on the quality of chipped product and fuel consumption. The research conducted contributed to designing more effective constructions of working units.

Another direction of improving the efficiency of these processes is the modification of the chipping wood machine drive. Mobile wood chippers are most often equipped with internal combustion engines. These engine are subject to technical and technical specifications of the European [Journal of Laws from 2014] relating to non-road mobile machines. These provisions concern emissions limits for toxic exhaust gases and 2019 will be tightened in accordance with Directive 2016/1628/EU [European Parliament and of the Council 2016]. These regulations, despite the exacerbation, will still be much more liberal than the regulations on passenger vehicles. This allows manufacturers of non-road machines to sell old construction technology.

Modern electronic fuel injection systems in automotive vehicles with spark ignition engines almost completely suppressed fuel supply systems using carburetors. This has contributed to the exploitation aspects, i.e. the introduced emissions limits for toxic exhaust gases and the economics of exploitation: fuel consumption, serviceability and durability of the system. Much more liberal emission regulations for toxic gas emissions in non-road mobile machines lead to widespread use by manufacturers of carburetors. The review of offered on the market engines for non-road mobile machinery in January 2017 shows that only 11% of spark ignition engines are equipped with electronic injection systems.

It is common practice for manufacturers to integrate the injection system with the ignition system, due to the duplication of signals from sensors used in process control. The advantages of using electronic ignition systems are: lower fuel consumption, less toxic compounds in the exhaust gases, improved combustion efficiency, increased power and torque of the engine, improved dynamic response to changing working conditions, reduced control and maintenance, Emergency Re-

sponse and Malfunction Indicator Lamp (MIL), facilitating system diagnosis by supporting diagnostic functions for monitoring of operating parameters and fault code records.

Among the major manufacturers of spark-ignition internal combustion engine engines for EFI electronic fuel injection are: Kohler Engines, Briggs & Stratton, Honda, Kawasaki, Subaru Robin, Yamaha. In addition, ECOTRONS manufactures modular kits for this type of engine, enabling the implementation of an electronic fuel injection system. The systems used vary from one another and differ from the standards of today's passenger vehicles that pioneer in the development of combustion engines.

2. EFI CONTROL SYSTEMS APPLIED TO PROPULSION OF NON-ROAD MOBILE MACHINERY

2.1. Kohler Engines- EFI system

Combustion engines with spark ignition equipped with EFI systems designed for propulsion of non-road mobile machinery offered by the company Kohler Engines they are types of Command PRO engines which are equipped with two types of electronic integrated injection-ignition systems: ECH-system and Bosch-system.

2.1.1. ECH EFI- system

The fundamental component of the ECH system is the electronic engine control unit ECU. Its main task is to determine the angle and time of fuel injection and the ignition angle to obtain a specific fuel-air mixture for the current operating conditions of the engine. Fuel pressure in the system is maintained at about 0.27 MPa. The injection is made to the intake manifold before the throttle. The injection time in the system according to the demand reaches a value from 2 to 12 ms.

The control process consists of monitoring the signals from the engine temperature sensor, rotational speed and position of the crankshaft and engine load based on the Throttle Position Sensor (TPS) signal. These are the main signals for the programmed fuel injection characteristics of the controller microprocessor. When the engine reaches operating temperature, the control starts taking into account information for example about the oxygen content of the exhaust gases. This signal allows the interpretation of the air fuel mixture generated, indicating whether it is rich or lean. This mode of operation allows the system to work in the feedback loop allowing adjustment to the desired composition of the fuel-air mixture. The ECH EFI system functions in the feedback loop when the following conditions are met:

- engine temperature (oil) is higher than 60 °C;
- the temperature sensor of the exhaust gas reaches at least 400 °C;
- the engine is in steady state.

Signals that the system continually interprets are: ignition switch, crankshaft position and speed, throttle position, engine temperature (oil), intake air temperature, exhaust temperature, oxygen level in the exhaust gas, absolute pressure in the intake manifold, and battery voltage. The ECU compares these input signals with the programmed characteristics in the controller memory to obtain the appropriate angular and injection timing values and the ignition angle depending on the conditions of exploitation. If the system is equipped with an MIL fault indicator, it is possible to read the fault code using the diagnostic trouble code.

The four-wire oxygen sensor with heater (signal, mass and two heating cables) that is installed the system generates a signal indicating whether the fuel-air mixture is rich or lean. The system has an idle regulation mechanism.

Basic actuators ECH EFI system are: eclectic fuel pump, fuel injectors, ignition coils, malfunction indicator lamp (MIL); spark plugs; whereas the basic sensors are: rotary speed sensor and position of the crankshaft sensor, throttle position sensor TPS, the oxygen content of the exhaust gas sensor, manifold absolute pressure sensor MAP, the engine temperature sensor (oil); Inlet air intake temperature sensor.

Other elements of the system are: diagnostic connector, electronic control unit **ECU; mechanical fuel pressure regulator; ignition switch; battery, high voltage cables, mechanical throttle** [Kohler Power Group 2017].

2.1.2. Bosch EFI- system

The Bosch EFI generates a working pressure of around 0.27 MPa. The injection is made to the intake manifold before the throttle and the injection time is from 1.5 to 8 ms. The Bosch system works in closed loop feedback when all three conditions are met:

- engine temperature (oil) is higher than 35 °C;
- the oxygen sensor in the exhaust gas reaches at least 475 °C;
- the engine is in steady state

The Bosch system does not include an intake manifold (MAP) absolute sensor and an intake manifold air temperature sensor. The oxygen sensor used in the flue gases is also four-wire, generating a voltage signal from 0.2 V to 1.0 V, indicating a lean or rich mixture. The system has an idle regulation mechanism.

Basic actuators of the Bosch EFI system are: electric fuel pump, fuel injectors, ignition coils, spark plugs, failure indicator light (MIL).

Basic sensors are: crankshaft position and engine rotational speed sensor, exhaust gas oxygen sensor, throttle position sensor (TPS), engine temperature sensor (oil).

The basic components of the system are: diagnostic connector, electronic control unit (ECU), mechanical fuel pressure regulator, ignition switch, battery, high voltage cables, and mechanical throttle [Kohler Power Group 2017].

2.2. Briggs & Stratton- EFI system

Briggs & Stratton's electronic injection and ignition systems are used in the Vanguard and Big Block engines. In addition, the manufacturer uses two types of injection and ignition systems 490 000 and 610 000 systems.

2.2.1. 490 000 EFI- system

The system at the start of the system makes a short pulse fuel injection, which facilitates the start-up of the device. After exceeding 300 rpm of the crankshaft, the system starts the control depending on the signals from the speed sensor and the crankshaft position; absolute pressure sensor in intake manifold and engine temperature sensor (oil temperature). In case the engine is not heated the fuel-air mixture is rich. The oxygen sensor used in the exhaust gas has a similar function as the ECH-system and also generates a binary signal. The system has two fuel pumps, the first mechanical vacuum that pumps fuel to the electric fuel pump. Basic components include spark plugs, ignition coils, ignition switch, battery, fuel injectors, electric fuel pump, MIL, TPS, MAP, engine temperature sensor oil, oxygen sensor in flue gases, inlet manifold temperature sensor, ECU, crankshaft position and speed rotational sensor, diagnostic connector, mechanical fuel pressure regulator, high voltage cables, mechanical throttle and idle regulation mechanism. [Briggs & Stratton 2017].

2.2.2. 610 000 EFI- system

The system is quite similar to 490 000 EFI system with two differences. The system is equipped with two electric fuel pumps. The second difference is idle regulation. The system is equipped with an electric idle valve that regulates the air flow through the additional throttle channel allowing for more precise engine control at idle speed than with mechanical flow control [Briggs & Stratton 2017].

2.3. Subaru Robin- EFI system

The Japanese manufacturer of engine dedicated for non-road mobile machinery in the designation of engines fitted with an electronic injection system, the FI designation is used. The control process and layout will be discussed on EX21 FI.

The system is only equipped with a mechanical vacuum fuel pump which is triggered by the vacuum generated in the crankcase of the engine. It does not have an oxygen sensor in the exhaust so it does not work in the feedback loop. The system also is not equipped with a battery, and the necessary energy is extracted from the magneto. At start up, the system takes into account the speed and position of the crankshaft, throttle position, temperature of sucked air and engine temperature based on the oil temperature. Idle regulation is achieved by using an electrically controlled throttle, which also performs an automatic suction function and monitors the temperature of sucked air [Subaru Industrial Power Products 2017].

2.4. Kawasaki EFI system

The electronic injection-ignition systems used by the Kawasaki manufacturer for engines that propels non-road mobile machines are DFI systems. DFI (Direct Fuel Injection) designation generally means high pressure injection of gasoline directly into the cylinder. The Kawasaki signature DFI (Digital Fuel Injection) is a digital fuel injection, which technologically is the EFI. The system will be described based on the FD791D DFI engine. It is not equipped with an oxygen sensor in the exhaust gas or a throttle position sensor. The damper is mechanically adjustable with mechanical idle control. The system has no crankshaft position sensors or rotational speed; these signals are taken from the ignition system. The base components of the system are electronic control unit (ECU), MAP sensor, engine coolant temperature sensor, intake manifold air temperature sensor, fuel injectors, spark plug, high voltage coil, alternator stator windings Ignition switch, battery, fuel pump relay, main relay, MIL, fuse, starter, electric fuel pump, high voltage cables, fuel pressure regulator, mechanical throttle [Kawasaki 2017].

2.5. Honda EFI system

Honda as one of the first manufacturers has developed an engine designed to propel non-road mobile machinery equipped with the EFI system, these engines are the iGX series, whose sales began in July 2005. The electronic control system con-

tinuously monitors the throttle tilt signal, rotational speed and crankshaft position. With the use of an electric throttle it is possible to maintain a constant speed regardless of the changing load conditions of the engine. The iGX440 engine performs at about 30% lower emissions than the US Environmental Protection Agency (EPA) and the California Air Resources Board (CARB). Fulfilling the highest standards of fuel-air mixture control in the world [Honda 2017, Honda gasoline engines 2017, Honda iGX270 and iGX390 2014].

Access to wider data and description of the system to identify the control process used in these engines is difficult. The largest paper instructions are deprived of information about the sensors used in the system, and the electrical schematics included in them are also lack information. Another way to identify the system is to access the service manual in a software form [Honda Diagnostic System 2017].

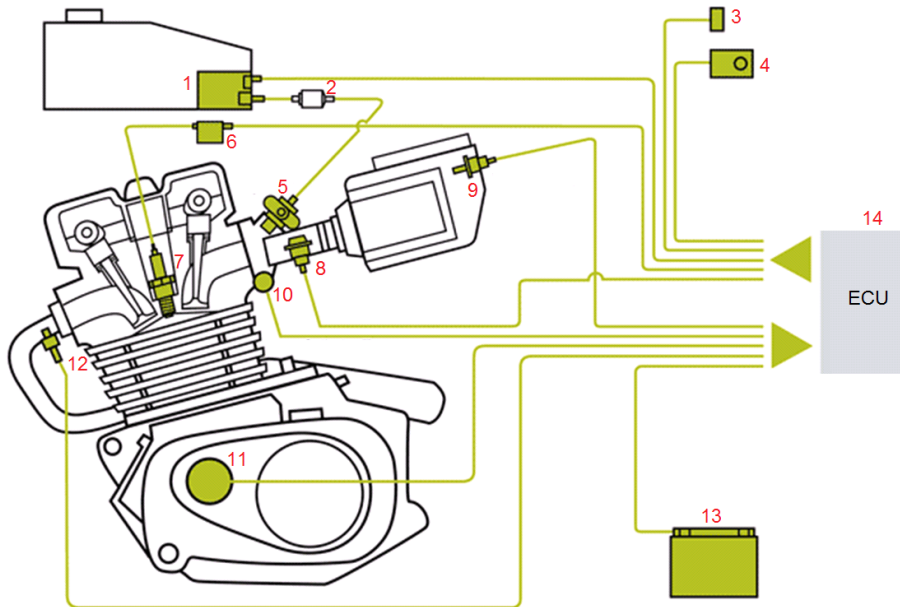

Fig. 1. Scheme of the ignition-injection system used in low-power engines being the subject of a Chinese project using the microprocessor MC33812 IC: 1 – electric fuel pump, 2 – fuel filter, 3 – diagnostic connector, 4 – malfunction indicator lamp, 5 – fuel injector, 6 – coil ignition, 7 – spark plug, 8 – manifold pressure sensor, 9 – inlet air intake temperature sensor, 10 – cylinder engine temperature sensor, 11 – position crankshaft position sensor and rotation speed sensor, 12 – oxygen sensor in exhaust gases, 13 – battery, 14 – electronic control unit [Johanson 2009]

2.6. Project of control system with microcontroller MC33812 IC

R. Colin Johnson in 2009 demonstrates that in Shenzhen, China, the MC33812 IC controller design has been developed to control the electronic ignition system as shown in Fig. 1. The system is expected to meet the Stage 3 emissions standards set by the Environmental Protection Agency (EPA) of the United States in 2015 for small internal combustion engines. The authors estimate that electronic engine control can reduce carbon monoxide emissions by 65%, hydrocarbons by 35%, and nitrogen oxides by 35% as compared to carburetors, while increasing power [Free-scale Semiconductor 2009, Johanson 2009]. There is no information on the sensors used: TPS throttle position, throttle type and oxygen sensor in the exhaust.

2.7. Modifications of ignition systems and fuel supply

By significantly improving the characteristics of the engines with the implemented electronic injection system, emerged companies specialized in the production of modifications to the control circuits of internal combustion engines. One of the major manufacturers of such systems is ECOTRONS. This company specializes in the production of electronic injection systems in the form of kits that are implemented in serial engines of various manufacturers. This company offers modular kits for engines from 35 cm³ to 300 cm³; From 400 cm³ to 800 cm³ and specific engine models ie Briggs and Stratton Junior 206; Kawasaki Ninja 250 cm³ and Honda GX35

The system is characterized by electronic fuel injection and feedback, allowing the emission of harmful emissions and fuel consumption to be reduced.

Depending on the setting of the system and the selection of subassemblies it allows to control one and two cylinder engines, feedback operation thanks to the oxygen density sensor in the exhaust, electric idle regulation, evaporation control of the fuel vapors from the tank using the evaporative emission system.

The controller can support crankshaft speed and positioning signals from inductive and hallotronic sensors, suction manifold suction pressure, throttle position, suction air temperature, engine temperature, oxygen content in exhaust gases, vehicle speed. The systems are equipped with mechanical throttle optionally with an electric idle control valve. The control unit is one for the ignition system or control of the injection and additionally sends a signal to the CDI (Capacitor Discharge Ignition) controller responsible for the ignition system. Four-wire oxygen sensors in exhaust gases are used in the systems [Auto Electronics and Engine Controls ECOTRONS 2017].

3. THE ANALYSIS OF THE STRUCTURES OF THE APPLIED EIF SYSTEMS

3.1. Used subassemblies, structure and systems

Characteristic elements of the design of injection-ignition systems used in engines for non-road mobile machines are presented in Table 1. It also refers to elements commonly used in motor vehicles, which are significantly higher in terms of operating requirements, especially ecological ones. It also refers to the elements commonly used in automotive vehicles for which operating requirements, especially environmental ones, are much higher.

Additionally, in order to improve the steering or ecological aspects of modern vehicles, Spark Ignition engines are commonly equipped with: three-way catalytic converter, several oxygen sensors in exhaust gases, nitrogen oxide sensor in exhaust gases, mass flowmeters: MAF (mass air flow meter) or hot wire mass airflow sensor, additional exhaust air extraction system for the exhaust manifold; exhaust gas recirculation system; systems of use of dynamic supercharging; boost: turbo, mechanical compressor or compressor type Comprex; start-stop systems, variable timing phases.

3.2 Functions and characteristics of subassemblies, structure and system

The EFI systems used in non-road mobile machines are also commonly used in passenger vehicles. In most cases they have been replaced by newer solutions or equipped with innovative systems.

Oxygen content in exhaust gases sensor (four – wire) generates a voltage impulse indicating if air-fuel mixture is rich or lean depending on the difference of oxygen concentration between exhaust gases and atmosphere. The latest resistance sensors for oxygen content in exhaust gases used in automotive vehicles i.e. Broadband lambda generates a signal proportional to the residual oxygen content in the flue gases. These sensors are typically five-wire and allow for more accurate control of combustion processes.

Exhaust systems are also fitted with catalytic converters designed to reduce emissions of toxic exhaust gas components. The TWC catalyst cleans exhaust gases from three toxic components: carbon monoxide, hydrocarbons and nitrogen oxides. In the catalytic reaction process there is a reduction of nitrogen oxides to nitrogen and oxygen. The latter is in turn used for the oxidation of carbon monoxide and hydrocarbons into carbon dioxide and water. Achieving high catalytic efficiency requires appropriate thermal conditions and maintenance of the stoichiometric composition of the fuel-air mixture.

A 2-way catalytic converters which are also used consist of two catalysts: tri-functional and oxidizing catalysts in series. Additional air is supplied between the catalysts. In the first phase, the system primarily reduces nitrogen oxides and oxidizes carbon monoxide and hydrocarbons into carbon dioxide and water in the second phase. The advantage of this solution is the lack of requirements concerning stoichiometric composition of the fuel-air mixture.

Table 1. Characteristic elements, components and systems of EFI systems of non-road mobile machinery and passenger vehicles

	Engine manufacturer:	Kohler Engines	
	EFI system:	ECH EFI	Bosch EFI
Characteristic elements, subassemblies and structure of the system	Fuel pump:	electric	electric
	Sensor for oxygen content in exhaust gases:	four-wire	four-wire
	Rotational speed sensor and the crankshaft position:	one inductive sensor	one inductive sensor
	Throttle Position Sensor TPS:	applied	applied
	Absolute pressure sensor in intake manifold MAP:	applied	not used
	Engine temperature sensor:	oil temperature	oil temperature
	Suction air temperature sensor:	applied	not used
	Electronic control unit ECU:	integrated injection-ignition system	integrated injection-ignition system
	Fuel pressure regulator:	mechanical	mechanical
	Battery:	applied	applied
	Throttle:	mechanical	mechanical
	Idle regulation:	mechanical	mechanical
	Location of the injector:	to the intake manifold	to the intake manifold
	Fuel vapor absorption system:	not used	not used

Table 1. Characteristic elements, components and systems of EFI systems of non-road mobile machinery and passenger vehicles, cont.

Briggs & Stratton		Kawasaki
490 000 EFI	610 000 EFI	FD791D (DFI)
two pumps: 1. mechanical vacuum 2. electric	two pumps: 1. electric 2. electric	electric
four-wire	four-wire	not used
one inductive sensor	one inductive sensor	not used- signal from the ignition system
applied	applied	not used
applied	applied	applied
oil temperature	oil temperature	coolant temperature
applied	applied	applied
applied	applied	applied, not integrated with the ignition system
mechanical	mechanical	mechanical
applied	applied	applied
mechanical	mechanical	mechanical
mechanical	electric idle control valve	mechanical
to the intake manifold	to the intake manifold	to the intake manifold
not used	not used	not used

Table 1. Characteristic elements, components and systems of EFI systems of non-road mobile machinery and passenger vehicles, cont.

Subaru Robin EX21 FI	Honda iGX	Chinese research project with microcontroller MC33812 IC
mechanical vacuum	–	electric
not used	–	applied
one inductive sensor	–	applied
applied	–	applied
not used	–	applied
oil temperature	–	cylinder temperature
applied	–	applied
integrated injection-ignition system	–	integrated injection-ignition system
mechanical	–	mechanical
not used	–	applied
electric	electric	no data
regulation of the tilt of the electrically controlled throttle	–	no data
to the intake manifold	–	to the intake manifold
not used	–	not used

Table 1. Characteristic elements, components and systems of EFI systems of non-road mobile machinery and passenger vehicles, cont.

ECOTRONS	Passenger vehicles
possibility of implementation kits	commonly applied
electric	1. electric 2. mechanical high pressure
four-wire	– at least one probe in the system – five-wire-broadband
One inductive sensor or one hall-effect sensor	– one inductive sensor or one hall-effect sensor on the crankshaft – at least one on the camshaft (crankshaft position)
applied	applied
applied	– applied or applied + air flowmeter or not used, replaced by air flowmeter
temperature: coolant, cylinder, oil	temperature: coolant, cylinder, oil, engine components eg screwed into the head
applied	applied
integrated injection-ignition system or the injection controller and the CDI driver responsible for the ignition system.	at least integrated injection-ignition system eg injection-ignition + timing phases control
mechanical	mechanical or electrovalve
applied	applied
mechanical	electric or not replaced by the "Valvetronic" system
mechanical or electric idle control valve	regulation of the damping of the electrically controlled throttle or suction valve stroke adjustment as in the "Valvetronic" system.
to the intake manifold	to the intake manifold
applied	applied

The exhaust air extraction system is used in the initial phase of the cold engine operation. During this phase, the engine is powered by a rich mixture, generating high emissions of toxic exhaust gas. The reason for this phenomenon is the thermal limitation of the range of operation of the catalyst and the oxygen sensor in the exhaust gas. At this time, additional exhaust air is added to the exhaust system, accelerating the start of the emission control system. Oxygen in the air is reacted with hot flue gas, oxidizing carbon monoxide and hydrocarbons to carbon dioxide and water, despite the lack of a catalyst. The resulting oxidation reaction causes a rapid increase in temperature and a shortening of the catalyst starting time and oxygen sensor in the exhaust gas, accelerating the initiation of the feedback loop control process.

Some systems use two oxygen sensors in the exhaust gas located before and after the catalyst. This system is designed to check the effectiveness of the catalyst. In addition, the systems are also equipped with a sensor for the nitrogen oxides content of the exhaust gases. This sensor continually monitors the content of nitrogen oxides in the exhaust gas, helping to regulate the mix and helping to assess the level of catalyst wear.

Another emission limiting system is the EGR (Exhaust Gas Recirculation). The principle of operation of the system base on the introduction of a certain amount of exhaust gas into the engine air supply system. This solution causes: accelerated evaporation of fuel; lowering the combustion temperature of the fuel-air mixture low in oxygen; oxidation of remaining unburned hydrocarbons remaining in the exhaust gas. The effect of the system is to reduce the emission of nitrogen oxides.

The engine idle regulation in the engines of modern vehicles has been replaced by an electrically controlled throttle; An electric idle valve allows air to flow through the additional throttle channel or "velvetronic" system, which allows the engine to run at idle. The "velvetronic" system is a system that changes the stroke of the intake valve in the engine timing, adjusting the amount of suction air, giving the option of eliminating throttle and idle valve.

Another commonly used system in modern vehicles is direct injection into the combustion chamber, using high-pressure mechanical fuel pumps. This type of injection is characterized by high fuel injection precision and the possibility of layered injection. In addition, this solution enables not only quantitative control, which is characteristic for positive-ignition engines but also qualitative ones.

Due to significant interference in engine designs during the design of direct injection engines for quality control, components will be discussed to support the fuel-air mixture quantitative control systems. In order to make adjustments, it is necessary to determine the amount of sucked air into the combustion chamber. Today, the volume measurement of the intake air has been replaced by mass flow meters. Then the control need not depend on the pressure and the temperature of the aspirated air. This type of measurement shows more favorable response time characteristics, resistance to pressure pulsations, does not throttle the flow and eliminates the wear of moving parts.

In quantitative control it is also necessary to adjust the amount of sucked air to the combustion chamber. The mechanical throttles common in the engines discussed in this paper were replaced by electrically controlled dampers in vehicles. These throttles are characterized by varying characteristics, thanks to which it is possible to regulate the operation of the motor according to a number of factors, allowing additional control at idle.

It is not common in engines dedicated to propel non-road machinery to use systems that allow to supply engine with higher amounts of working factor (air or fuel-air mixture). Such process is called charging and it leads to introducing into combustion chamber additional working factor of higher density, that allows for combusting high doses of air-fuel mixture.

This allows for increased engine power at the same geometrical dimensions. This charging may be obtained in four different ways: with the use of charger propelled by internal-combustion engine (turbocharging), charger propelled by crankshaft (the Roots displacement pump); pressure wave supercharger (Comprex system) and dynamic charge that uses air waves flows thanks to changeable length of intake manifold.

The system that seems to be the ideal solution for engine designed to propulsion non-road mobile machines is the vapor recovery system. Due to the fact that these devices are operated periodically, and to protect the fuel tank against corrosion, they are left with a full fuel tank, which emits harmful vapors. These are aliphatic and aromatic hydrocarbons, which contribute to the formation of strong oxidants such as ozone causing respiratory and eye diseases. The limitation of emissions of these vapors is to help a system that absorbs fuel vapors from the tank and then automatically purifies by transferring them to the intake system. The absorber in this system is an activated carbon container that absorbs the vapors coming to it as a result of the vapor pressure increase.

4. SUMMARY

The presumed tendency of the development of injection engines for propulsion of non-road mobile machinery will lead to the usage of subassemblies and systems used in vehicles

This tendency will continue as the legal norms that introduce harmful emissions limits for vehicle engines are much more stringent. This situation forces vehicle manufacturers to significantly develop their design to reduce emissions and improve efficiency. At the same time, regulations for engines with applications other than road are tightening up, but these regulations are much more liberal. Systems such as variable valve timing, direct fuel injection, and "Velvetronic" require significant redevelopment of the structure, which can lengthen their deployment time in non-road applications. Modifications to the system by implementing more inno-

vative components such as the introduction of a wideband oxygen sensor in the exhaust gas should be relatively quick. Other structure and systems ie fuel vapor control, catalytic three-function catalytic converter, several oxygen sensors in exhaust gases, nitrogen oxide sensor in exhaust gases, mass flowmeters, exhaust air extraction system, exhaust gas recirculation system, systems using dynamic charging, they will be implemented systematically, where environmental mitigation schemes will take precedence over homologation requirements. Currently, the systems in engines designed to propulsion non-road mobile machines are from carburettor systems to relatively simple integrated fuel injection systems to the suction manifold, but they account for about 11% of the sales offered.

REFERENCES

- Adamchuk V., Bulgakov V., Skorikov N., Yezekyan T., Olt J., 2016, Developing a new design of wood chopper for grape vine and fruit tree pruning and the results of field testing, *Agronomy Research* 14(5), p. 1519-1529.
- Auto Electronics and Engine Controls ECOTRONS, http://www.ecotrons.com/products/small_engine_fuel_injection_kit/ (access on: 03.2017).
- Briggs & Stratton gasoline engines, https://www.briggsandstratton.com/na/en_us/products/engines.html (access on: 03.2017).
- Dias A.B., Patrocinio S., Pereira S., Brites T., Pita V., Barroso J.M.M., 2015, Evaluation of the Use of a Disc-Saw Machine in Winter Pruning 'Rocha' Pears Orchards – an Account of Five Years. Conference: 12th International Pear Symposium, Location: Leuven, Belgium, Date: July 14-18, 2014, XII International Pear Symposium, Book Series: Acta Horticulturae, Vol. 1094, p. 281-288.
- Fortuna-Antoszkiewicz B., Gadomska K., Gadomski K., 2010, Decoration and maintenance of green areas (original title in Polish: Urządzanie i pielęgnacja terenów zieleni), pt. 3, ed. 2, Hortpress, Warszawa
- Freescale Semiconductor – User's Guide, 2009, Small Engine Reference Design User Manual, Featuring the MC33812 nad MC9S12P128, NXP, Document Number: KT33812ECUUG, Rev. 3.0, 11/2009, <http://www.nxp.com/assets/documents/data/en/user-guides/KT33812ECUUG.pdf>.
- Honda, <http://www.environment.honda.eu.com/reports/Honda%20Environmental%20Report%202005.pdf> (access on: 03.2017).
- Honda Diagnostic System, http://www.brpdiagnostics.com/site_files/442/Dr%20H%20User%20Manual.pdf (access on: 03.2017).
- Honda gasoline engines, <http://engines.honda.com/models/> (access on: 03.2017).
- Honda gasoline engines iGX270, iGX390 – owner's manual 2014, <http://cdn.power.equipment.honda.com/engines/pdf/manuals/00X37Z8R8030.pdf> (access on: 03.2017).
- Johnson C.R., 2009, Small engines get greener, Designlines Automotive, http://www.eetimes.com/document.asp?doc_id=1312881
- Journal of Laws from 2014, No. 0, item 588 (original title in Polish: Dz. U. z 2014 r. Nr 0, poz. 588), Regulation of the Ministers of Economy On 30 April 2014. On the detailed

- requirements for internal combustion engines to reduce the emission of gaseous and particulate emissions for these engines.
- Kawasaki gasoline engines, <http://www.kawasakianginesusa.com/engines> (access on: 03.2017).
- Kohler Power Group gasoline engines, <https://power.kohler.com/na-en/engines/engines> (access on: 03.2017).
- Municipal Office in Gliwice, Nursing of trees and shrubs in the light of the Nature Conservation Act (original title in Polish: Pielęgnowanie drzew i krzewów w świetle ustawy o ochronie przyrody), <https://bip.gliwice.eu/strona=10612> (access on: 03.2017).
- Naimi L.J., Sokhansanj S., Mani S., Hoque M., Bi T., Womac A.R., Narayan S., 2006, Cost and performance of woody biomass size reduction for energy production, CSBE/SCGAB Annual Conference, Edmonton Alberta, July 16–19, 2006, paper No. 06-107, p. 1-13
- Nati C., Spinelli R., 2010, How blade wear of chippers can affect fuel consumption and wood chip size distribution, Forest engeneering: Meeting the Needs of the Society and the Environment, FORMEC 2010, July 11–14, 2010, Padova–Italy, p. 1-7.
- Nati C., Spinelli R., Fabbri P., 2010, Wood chips size distribution in relation to blade wear and screen use. Biomass and Bioenergy, Vol. 34, Iss. 5, p. 583-587, doi:10.1016/j.biombioe.2010.01.005.
- Przybylko J., 2013, The applications of autonomous systems to forestry management, Massachusetts Institute of Technology, <http://hdl.handle.net/1721.1/81014>.
- Regulation 2016/1628/UE of the European Parliament and of the Council of 14 September 2016. On requirements for emission limit values of gaseous and particulate pollutants and type-approval with respect to internal combustion engines for mobile machines non-road, amending Regulations (EU) No 1024/2012 and (EU) No 167/2013 and amending and repealing Directive 97/68/WE
- Spinelli R., Magagnotti N., Paletto G., Preti C., 2011, Determining the impact of some wood characteristics on the performance of a mobile chipper, Silva Fennica, Vol. 45, No. 1, p. 85-95.
- Stassen P.J.C., 2015, Development of Pruning and Training Systems for Higher Density Peach Orchards in South Africa, Conference: 8th International Peach Symposium, Location: Matera, Italy, Date: June 17-20, 2013-2016, VIII International Peach Symposium, Book Series: Acta Horticulturae, Vol. 1084, p. 343-350.
- Szczepanowska H.B., 2015, Good practices in the development of urban space with green infrastructure, especially with trees (original title in Polish: Dobre praktyki w zakresie zagospodarowania przestrzeni miejskiej zieloną infrastrukturą, zwłaszcza drzewami) Miasto idealne – miasto zrównoważone, Planowanie przestrzenne terenów zurbanizowanych i jego wpływ na ograniczenie skutków zmian klimatu, pod red. Kalinowskiej A., pt. 2, B. Podejście ekosystemowi do miast – usługi na rzecz adaptacji do zmian klimatu, p. 201-209, Warszawa.
- Tombesi S., Farinelli D., Molfese M., Cipolletti M., Visco T., 2014, Pruning Technique in Young High Density Hedgerow Olive Orchards. Conference: 7th International Symposium on Olive Growing, Location: San Juan, Argentina, Date: September 25-29, 2012. VII International Symposium on Olive Growing, Book Series: Acta Horticulturae, Vol. 1057, p. 385-390.
- Subaru Industrial Power Products gasoline engines, <http://www.subarupower.com/products/#generators> (access on: 03.2017).

Velazquez-Marti B., Fernandez-Gonzalez E., 2010, The influence of mechanical pruning in cost reduction, production of fruit, and biomass waste in citrus orchards, *Applied Engineering in Agriculture*, Vol. 26, Iss. 4, p. 531-540.

SYSTEMY STEROWANIA ELEKTRONICZNYMI UKŁADAMI WTRYSKOWO-ZAPŁONOWYMI W NAPĘDACH POZADROGOWYCH MASZYN RUCHOMYCH

Streszczenie

Napędy mobilnych maszyn roboczych przeznaczonych do rozdrabniania odpadów drzewnych to głównie silniki spalinowe. Od ich konstrukcji w głównej mierze zależy efektywność procesów rozdrabniania. Liberalne przepisy homologacyjne dotyczące silników spalinowych o zastosowaniu do pozadrogowych maszyn ruchomych prowadzą nie tylko do stosunkowo wysokich emisji szkodliwych związków spalin, ale również nie wymuszają na producentach rozwoju technicznego tych konstrukcji. Napędy te są pozbawione, systemów, układów i podzespołów charakterystycznych dla współczesnych konstrukcji stosowanych w pojazdach osobowych wyróżniających się wysoką efektywnością przy niskiej emisji zanieczyszczeń do środowiska. W artykule przedstawiono przegląd najnowocześniejszych systemów sterowania układem zapłonowo-wtryskowym stosowanych w silnikach spalinowych o zapłonie iskrowym przeznaczonych do napędu pozadrogowych maszyn ruchomych. Z przeglądu pięćdziesięciu siedmiu producentów tego typu silników przeprowadzonego w styczniu 2017 roku tylko sześciu oferuje silniki z układem wtryskowym. Zebrane dane o układach odniesione do pojazdów samochodowych wykazały, że konstrukcje oferowane przez producentów jako innowacyjne są konstrukcjami nadal znacząco odbiegającymi od współczesnych standardów. Dodatkowo analizie poddano dostępne systemy modernizacyjne układów oraz prowadzone projekty badawcze. Wyniki z przeprowadzonej analizy będą podstawą do modyfikacji istniejących konstrukcji.

Słowa kluczowe: pozadrogowe maszyny ruchome, mobilne maszyny robocze, sterowanie silnikiem spalinowym, układ wtryskowo-zapłonowy, silnik spalinowy o zapłonie iskrowym