

Michał GOŁĘBIEWSKI*

(Received 20 July 2015; Accepted 9 November 2016)

INCREASING IN EFFICIENCY OF USE OF NATURAL GAS INTO THE SUPPLY OF ELECTRICITY AND HEAT LARGE BUILDING ON THE EXAMPLE OF THE DEPARTMENT OF CHEMISTRY AT POZNAN UNIVERSITY OF TECHNOLOGY

The article presents the results of the technical and economic use of cogeneration technologies designed to increase the efficiency of use of natural gas to produce electricity and heat for the needs of large objects. The arrangement shown is part of the distributed generation of electricity and heat. As a supplement can be used such systems as ORC systems, heat pumps, solar collectors and photovoltaic cells. The object of study is a building of the Faculty of Chemical Technology, located on the campus of Poznan University of Technology. The economic analysis was conducted by comparing the costs of operating the above-mentioned devices with traditional methods of energy supply.

Słowa kluczowe: cogeneration, distributed energy production

1. INTRODUCTION

Nowadays, it becomes very important to implement technologies to limit use of fossil fuels. This is due to the limited resources of these raw materials as well as the escalation of restrictions on emissions of greenhouse gases such as CO₂. Carbon dioxide is the main product of combustion so the increase in efficiency of use of energy contained in fuels significantly reduces its emissions.

One of the most popular methods for improving the use of primary energy are cogeneration systems. In them occurs the process of changing the energy of fuel into electrical energy and heat which is transferred to the receiver as opposed to traditional systems. Currently most widespread cogeneration systems are CHP plants. They are located mainly in residential areas or in the vicinity where you can easily

* Poznan University of Technology.

find industrial heat consumers. Unfortunately, in such cases, there are losses in the transmission of electricity and heat. To solve this problem are used high efficiency cogeneration units which power does not exceed 1MW_{el} . Most are gas engines for mechanical efficiency of more than 40% connected to the heat exchanger that transfers the heat from the exhaust, oil and engine cooling system. Amount of obtained heat can reach 50% of primary energy and thus overall system efficiency can reach 80–90%. It should be added that the main recipients of generated power are located in the same place as the system of energy production so their transmission losses are minimal [1].

The technical and economic analysis of application of cogeneration system for energy supply of large buildings on the example of the building Faculty of Chemical Technology (FCT) at Poznań University of Technology (PUT) has been made and the results are presented below.

2. DESCRIPTION OF THE FCT BUILDING

The priority source of heat for the building is a cogeneration unit based on a gas engine. It is assisted in winter by peak gas boilers.

In this project a connection to the electricity grid is addition installed, so peaks of electricity demand are covered and in the case of repairs or breakdown of the cogeneration unit total supplies of building electricity can be covered with this connection.

Figure 1 was shown the schematic of the power supply of electricity and heat to the building of the Faculty of Chemical Technology of the Poznan University of Technology. Gas reducing station (1) power cogeneration unit (2) and peak gas boilers (3). The electricity and heat goes into the FCT building. Additional sources of electricity are connections of electricity from the transformer of Poznan University of Technology (4) and Enea grid (5).

Energy demand of the building has been developed based on design assumptions of the building. These assumptions include heat for heating the building (i.e. the classrooms, staff rooms, corridors) and the heat required for domestic hot water production. In addition, it provided the heat required for technological processes carried out at the premises of the building. Demand for electricity also includes a power that should be supplied to the compressor heat pumps which generate additional heat during the heating and chilled water for the summer period. Below are the individual points of consumption.

a) The demand for heat

The heat demands throughout the year are shown in Table 1. Knowing the target of heat demand of the building and climate zone in which building is located it is possible to calculate the average monthly energy consumption. It is possible to do this knowing average monthly temperatures of recent years and the knowledge of heat loss of the building. Moreover it was estimated of coefficient

of actual need for domestic hot water (DHW) which is $a = 0,25$. On the basis of these data it was created a graph of the average monthly demand for building thermal power (Fig. 2).

Table 1. Balance thermal sheets for building FCT

System	Power system (kW _{th})
Central heating and technical heat	1950
DHW (Domestic Hot Water)	450
Total heat demand	2400
DHW with factor $a = 0,25$	113

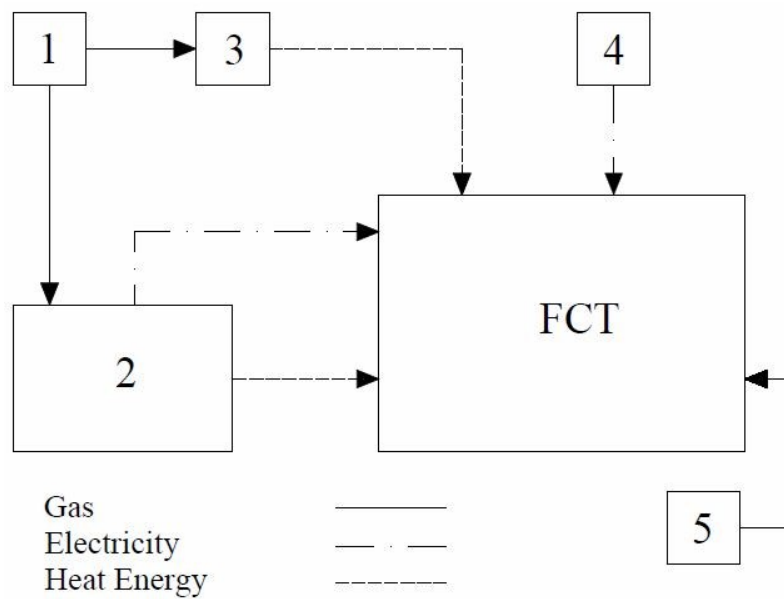

Fig. 1. Scheme of a cogeneration power building FCT: 1 – gas reducing station, 2 – gas engine, 3 – gas boiler, 4 – transformer, 5 – energy network

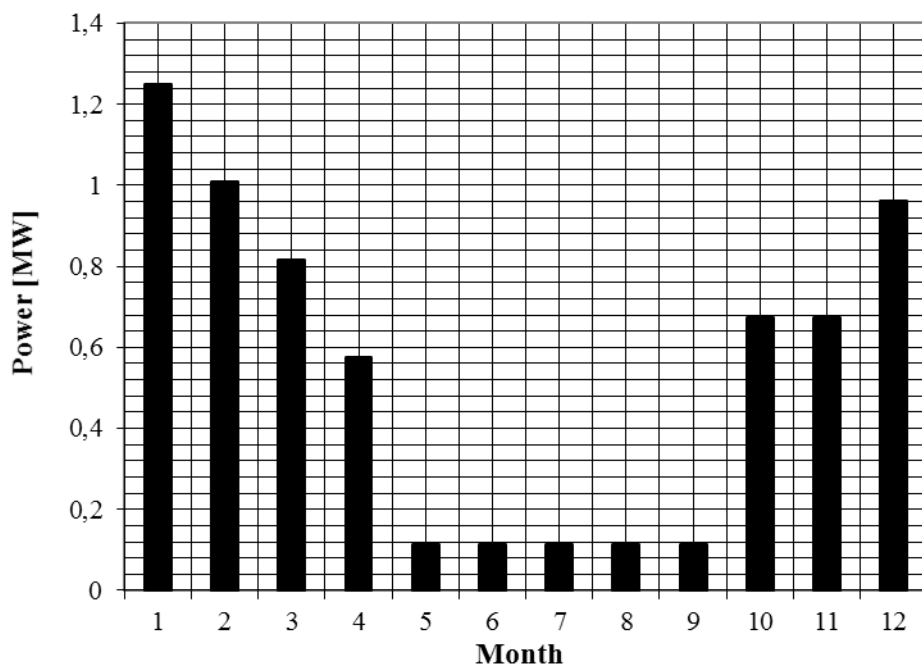

Fig. 2. Calculated average amount of heat energy for heat in the building during the year for FCT

On the basis of these data there have been developed as orderly graph of heat demand of building FCT. It is presented in Fig 3.

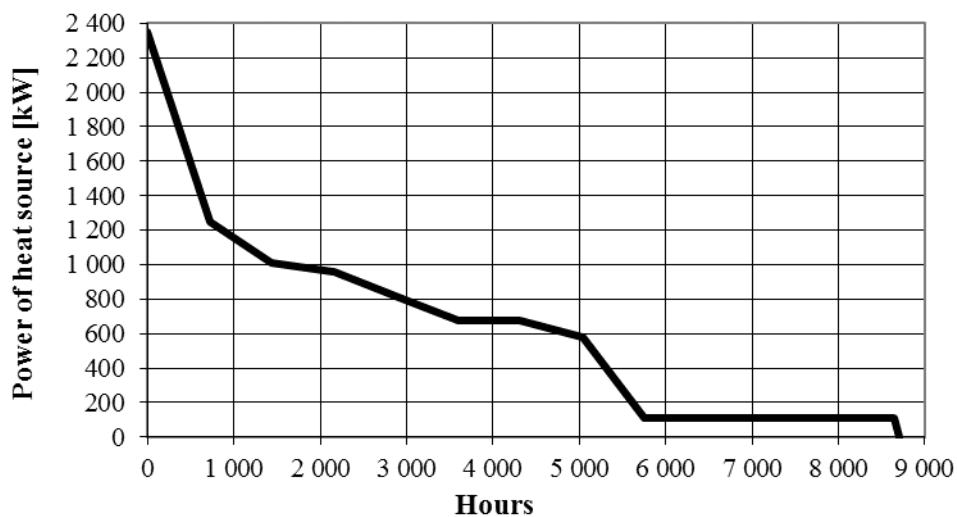

Fig. 3. An ordered graph of the heat demand of the building FCT

a) Demand for electricity required by design of the building is 1250 kW_{el}.

Knowing the demand for electricity and heat it is possible to make a selection of devices. The gas engine selection was based on the graph in Fig. 3. It consisted in determining the maximum power which is consumed as long as possible in time. This selection ensures treatment the engine will operate at maximum efficiency for the longest possible time. Below is a list of chosen devices:

b) Cogeneration unit of General Electric, model JMC 412 GS-NL with the power of 888 kW_{el}, thermal capacity 888 kW_{th} and the overall efficiency of 85.6%

c) Two gas boilers Buderus, model G615 with thermal power 970 kW_{th} and 645 kW_{th}; efficiency equal to 94.5%

d) Connection to the Enea grid of 850 kW_{el}

3. ECONOMIC ANALYSIS

Economic analysis of proposed technical solution compared with the traditional system consisting of delivery to the building electricity and heat from the city. The possibility of obtaining heat from the heat pump in combination with ground heat exchangers is also assumed.

Data from systems manufacturers and selected sellers energy from the city was used for the analysis. It was necessary to compare the GJ price of heat from the power plant to heat from the gas engine assisted by gas boilers. Similarly proceed with electricity but in this case the electricity shortage will continue to be covered by the connection of the power grid of the city. In addition, the certificates of origin of electricity were used. Anyone who produces electricity from sources other than traditional may apply for a grant. These costs are categorized into:

a) Investment costs	
– gas-engine	3,4 mln PLN
– gas boilers	230 thous. PLN
– electrical connection	144,6 thous. PLN
– Together	3,8 mln PLN
b) Operational costs [4, 5]	
– the cost of natural gas	4,4 mln PLN/a
– cost of electricity	1,4 mln PLN/a
– the cost of equipment operation	284 thous. PLN/a
– Together	6,1 mln PLN/a

- c) Certificates [6, 7]
 – cogeneration system 0,824 mln PLN/a

Traditional system entails the following financial expenditures and operating costs [3, 4]:

- a) Investment costs 1,88 mln PLN
 b) The cost of operating 5,797 mln PLN/a

The analysis of the effectiveness of the project was performed using the method of UNIDO [2], in which the value of financial flows is discounted at the assumptions:

- a) Comparative period 15 years
 b) The discount rate 5,5%

The result of analysis is shown in Figure 4.

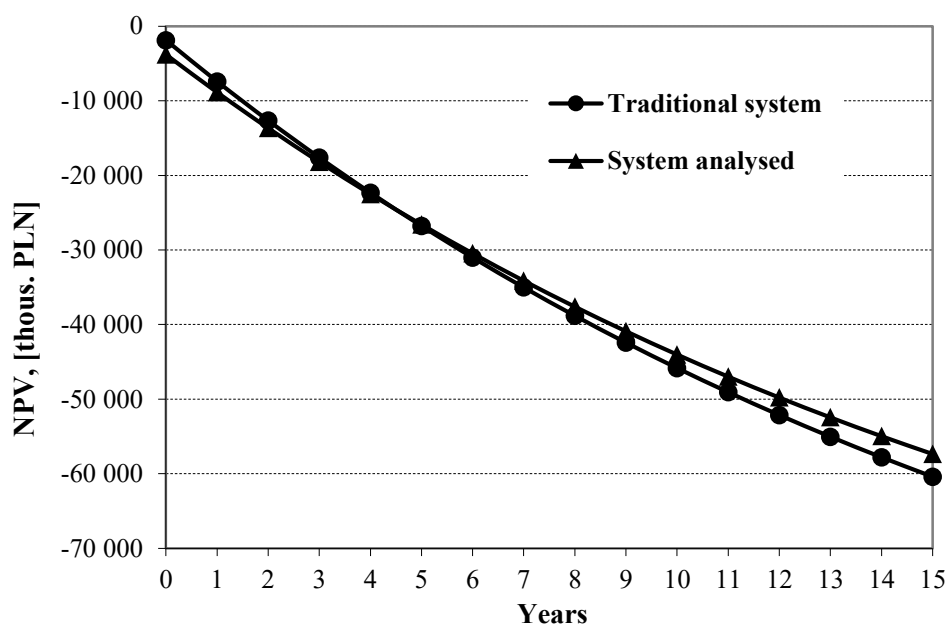

Fig 4: Discounted cash flow. The graph shows how long the overall cost of installation and cost of using of individual systems is equal. In this example it is 4,5 year

From the above graph $NPV = f(t)$ it results that the return on investment made by the proposed system is approximately 4,5 years.

3. CONCLUSIONS

The technical and economic analysis, in which a comparison was made of two variants of a classroom building FCT supply of heat and electricity shows the profitability of the use cogeneration system.

Payback time by the proposed technological solution (cogeneration system, gas boilers), taking into account changes in the value of money in time is approximately 4,5 years. This result owes a grant resulting from the possession of certificates of origin of electricity produced. Note however that the future of these certificates is not guaranteed, and before the time of return investments they lose value or be abolished. In this case, the system presented will generate losses compared to the conventional system. They will mainly cause by gas prices which for supply piston engines are higher than the standard applications.

REFERENCES

- Dobski T., 2012, Analysis of the possibility of supply in electricity and heat large buildings based on energy extracted from natural gas”, Gazterm 2012 Międzyzdroje 14-16 May.
- Matkowski A., 2013, Vademecum of Gas vol. IV. Natural gas: the market, efficiency and safety, wyd. SITPNiG.
- Tariff Dalkia Group SA valid from the date 01.01.2014 r.
- Tariff group Enea SA No 46/2014 of 17 December 2013 approved by the President of the Energy Regulatory Office.
- Changing the tariffs for PGNiG SA gaseous fuels Part A, in terms of supply of gaseous fuels nr. 6/2014; Warsaw, December 2013 approved by the President of the Energy Regulatory Office.
- Power Stock Market, www.polpx.pl.
- Energy Regulatory Office, www.ure.gov.pl.

ZWIĘKSZENIE EFEKTYWNOŚCI WYKORZYSTANIA GAZU ZIEMNEGO W ZASILANIU W ENERGIĘ ELEKTRYCZNĄ I CIEPŁO DUŻYCH OBIEKTÓW NA PRZYKŁADZIE BUDYNKU WYDZIAŁU TECHNOLOGII CHEMICZNEJ POLITECHNIKI POZNAŃSKIEJ

Streszczenie

W artykule przedstawiono wyniki analizy techniczno-ekonomicznej zastosowania technologii wysokosprawnej kogeneracji mającej na celu zwiększenie efektywności wykorzystania gazu ziemnego w celu produkcji energii elektrycznej oraz ciepła na potrzeby du-

zych obiektów. Przedstawiony układ jest jednym z elementów rozproszonego wytwarzania energii elektrycznej oraz ciepła. Jako uzupełnienie można wymienić takie układy jak pompy ciepła, kolektory słoneczne czy ogniwa fotowoltaiczne. Obiektem zaopatrywanym w energię jest budynek Wydziału Technologii Chemicznej znajdujący się na terenie Politechniki Poznańskiej. Analiza ekonomiczna przeprowadzono na podstawie porównania kosztów eksploatacyjnych wyżej wymienionych urządzeń z tradycyjnymi metodami dostarczania energii.

Słowa kluczowe: kogeneracja, rozproszone wytwarzanie energii